

**NOTES:**

- A. SLOPES MAY BE CHECKED WITH A 2-FOOT SMART LEVEL.
- B. RAMPS SHALL HAVE A HEAVY BROOM FINISH TRANSVERSE TO THEIR SLOPE.
- C. NO PULL BOX, UTILITY VAULT, UTILITY POLE, MANHOLE OR SIMILAR APPURTENANCE SHALL BE LOCATED WITHIN THE RAMP AREA WITHOUT PRIOR WRITTEN APPROVAL BY THE CITY ENGINEER.
- D. THE LANDING AREA SLOPE SHALL NOT EXCEED 1.75% IN ANY DIRECTION.
- E. TRANSITIONS TO SIDEWALK, GUTTER AND STREETS SHALL BE FLUSH AND FREE OF ABRUPT CHANGE.
- F. RAMP SHALL BE DESIGNED AND CONSTRUCTED SUCH THAT WATER DOES NOT ACCUMULATE ON RAMP.
- G. DETECTABLE WARNING SURFACE SHALL EXTEND THE FULL WIDTH OF THE RAMP LESS A MAXIMUM OF 2" ON EACH SIDE.
- H. THE LEADING EDGE OF THE DETECTABLE WARNING SURFACE SHALL BE LOCATED 6" TO 8" FROM THE GUTTER FLOW-LINE. DETECTABLE WARNING SURFACES SHALL BE INSTALLED PARALLEL TO THE PATH OF TRAVEL, AND SHALL EXTEND THE FULL WIDTH OF THE LANDING AREA, AND A MINIMUM DEPTH OF 3' FROM THE LEADING EDGE TOWARDS THE BACK OF THE LANDING AREA.

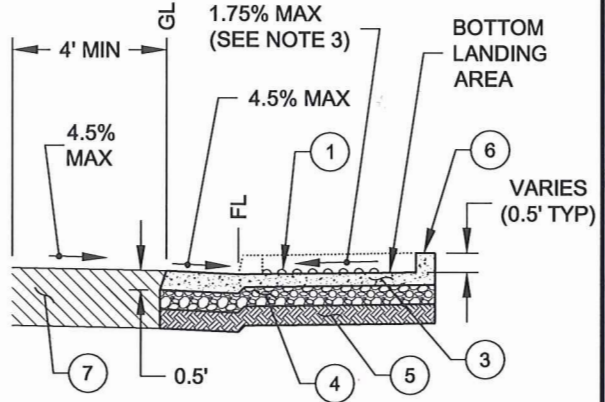

①	DETECTABLE WARNING SURFACE (SEE STANDARD DETAIL #210 AND NOTES G & H ABOVE).
②	DEEP TOOL JOINT - 1½" MIN DEPTH
③	4" 4,000 PSI MIN. CONCRETE
④	6" CLASS 2 AB (¾" MAX.) PROCESSED TO 95% RELATIVE COMPACTION

⑤	6" SUBGRADE OR CLASS 2 ASB PROCESSED TO 95% RELATIVE COMPACTION
⑥	6" WIDE RETAINING CURB WITH VARIABLE HEIGHT ALONG RUNNING SLOPE
⑦	STRUCTURAL STREET SECTION PER DESIGN STANDARDS

**THE CITY OF WEST SACRAMENTO - STANDARD DETAIL**



STANDARD  
DETAIL #  
**208**

TITLE:  
**PARALLEL CURB RAMP  
NEW CONSTRUCTION**



DATE APPROVED: July 28, 2015